



User's Manual of BLAZING LINK

LOADING...

Table of Contents

1. Game Information	1
2. Business Record	2
3. Game History	4
4. Event Record	9
5. Settings	10
6. Volume Setting.....	17
7. Input Test.....	18
8. Touch Calibrate.....	19
9. Time and Date	20
10. Reboot Machine.....	21
11. Exit Setup	21
12. Connection Diagram Of JP Sever	22
13. Connection Diagram Of Blazing Link	23
14. Warning Prompts	25

1. Game Information

1) After the device is turned on, enter the back-end and select **【Game Information】** to view game information

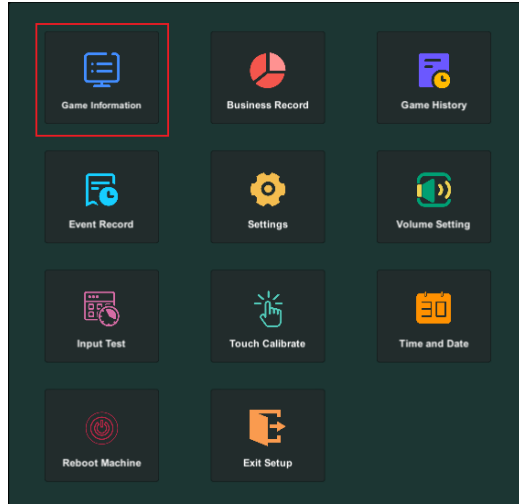

<Figure 1>

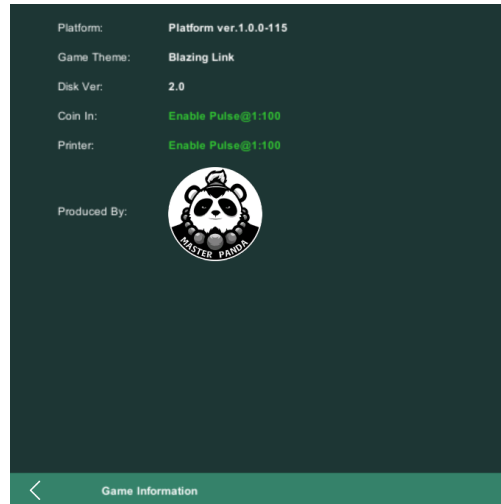

<Figure 2>

Game Information		
1	Platform	Platform Version Number (Platform ver.1.0.0-115)
2	Game Theme	Blazing Link
3	Disk Ver	32 bit system display 1.0; 64 bit system display 2.0
4	Coin In	(Enable Pulse@1:100) Indicates that 1 coin is 100 points
5	Printer	(Enable Pulse@1:100) Indicates that 1 coin redeemed is 100 points
6	Produced By	Manufacturer
7	<	Click it to go back to the main page of back-end

2. Business Record

1) Enter the back-end and select **【Business Record】** to view business records

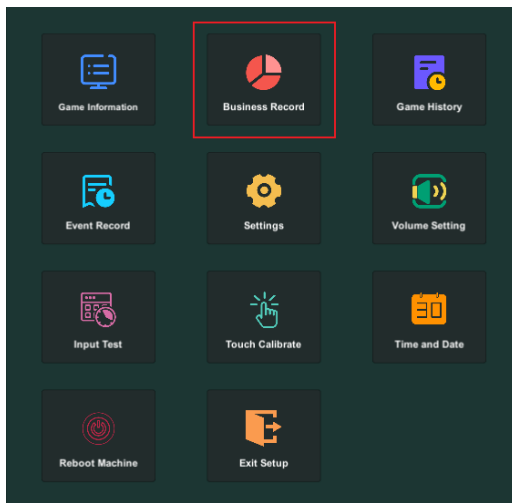

<Figure 3>

A screenshot of the 'Business Record' data table. The table has three columns: PERIOD METERS, PREVIOUS PERIOD METERS, and LIFETIME METERS. It displays various metrics such as Started/Ended times, Credit In, Redeem, Hold Rate, Play, Win, Jackpot, and Win Rate.

	PERIOD METERS	PREVIOUS PERIOD METERS	LIFETIME METERS
Started:	2025-10-28 15:50:02	2025-10-28 15:50:02	2025-10-28 15:50:02
Ended:	2025-10-29 11:35:10	2025-10-28 15:50:02	2025-10-29 11:35:10
Credit In:	\$18.00	\$0.00	\$18.00
Redeem:	\$0.00	\$0.00	\$0.00
Hold Rate:	100.00%	0.00%	100.00%
Play:	\$2.75	\$0.00	\$2.75
Win:	\$0.69	\$0.00	\$0.69
Jackpot:	\$0.00	\$0.00	\$0.00
Win Rate:	25.09%	0.00%	25.09%

<Figure 4>

A screenshot of the 'Business Record' table with a sidebar menu on the left. The sidebar includes options like Close, Print Period, Print Previous, Print Lifetime, Clear Period, Clear Lifetime, and Shift. The table data is identical to Figure 4.

	PERIOD METERS	PREVIOUS PERIOD METERS	LIFETIME METERS
Started:	2025-10-28 15:50:02	2025-10-28 15:50:02	2025-10-28 15:50:02
Ended:	2025-10-29 11:35:10	2025-10-28 15:50:02	2025-10-29 11:35:10
Credit In:	\$18.00	\$0.00	\$18.00
Redeem:	\$0.00	\$0.00	\$0.00
Hold Rate:	100.00%	0.00%	100.00%
Play:	\$2.75	\$0.00	\$2.75
Win:	\$0.69	\$0.00	\$0.69
Jackpot:	\$0.00	\$0.00	\$0.00
Win Rate:	25.09%	0.00%	25.09%

<Figure 5>

Business Record		
1	PERIOD METERS	Data of the current period meters
2	PREVIOUS PERIOD METERS	Data of the previous period meters
3	LIFETIME METERS	The sum of all period meters
4	Started	Start Time

5	Ended	End Time
6	Credit In	Data of Credit In
7	Redeem	Data of Credit Out
8	Hold Rate	PERIOD METERS> Current period meters(Credit In - Credit Out) /Credit In PREVIOUS PERIOD METERS> Previous period meters (Credit In - Credit Out) / Credit In LIFETIME METERS> All Period meters (Credit In - Credit Out) / Credit In
9	Play	Credits played
10	Win	Credits won from other than Jackpot
11	Jackpot	Credits won from Jackpot
12	Win Rate	PERIOD METERS> Current period meters (WIN+JACKPOT)/PLAY PREVIOUS PERIOD METERS> Previous period meters (WIN+JACKPOT)/PLAY LIFETIME METERS> All period meters (WIN+JACKPOT)/PLAY
13		Click it to enter the setting page
14	Close	Close the settings page and return to the business records page
15	Print Period	Print all data for the current period meters
16	Print Previous	Print all data for the previous period meters
17	Print Lifetime	Print all data for all period meters
18	Clear Period	Clear all data for the current period meters
19	Clear Lifetime	Clear all data for all period meters
20	Shift	Submitting the date of current period meters to the previous period meters, requires administrator password (Initial Password: 11111111)
21	<	Return to the main back-end page

3. Game History

1) Enter the back-end and select **【Game History】** to view game history

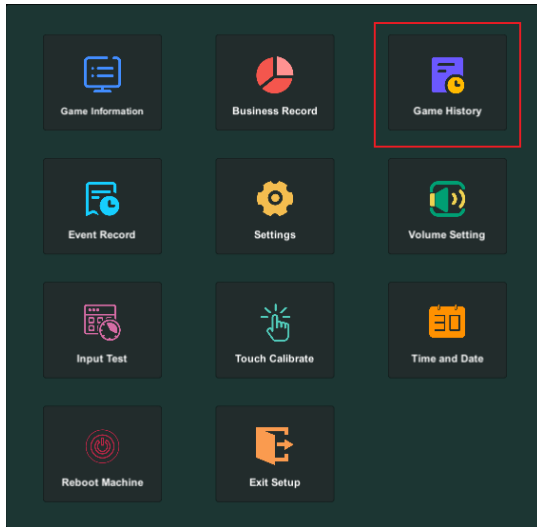

<Figure 6>

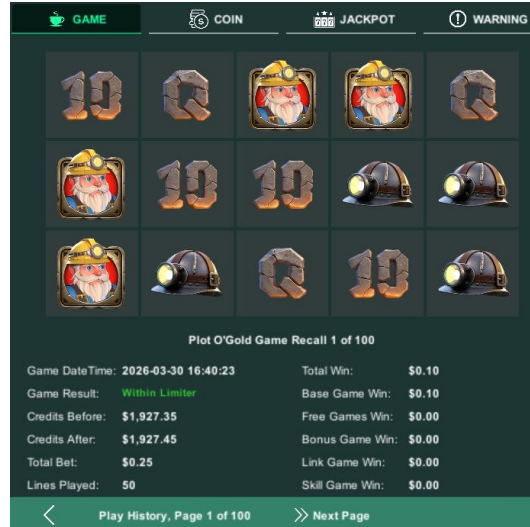

<Figure 7>

Game		
1	Plot O' Gold Game Recall 1 of 100	Game name+current page No.+ total page No.
2	Game Date Time	The start time of the game
3	Game Result	Game Result
4	Credits Before	Credits before play game
5	Credits After	Credits after play game
6	Total Bet	Total Bet
7	Lines played	50 Line
8	Total Win	Total Win
9	Base Game Win	Won in regular game
10	Free Games Win	Won in Free game
11	Bonus Game Win	Won in Bonus game
12	Link Game Win	Won in Link Bonus
13	Skill Game Win	Won in skill game

14	<	Click it to return to the main back-end page
15	Play History, Page 1 of 100	Play history, current page No., and total page No.
16	>>Next Page	Go to next page

2) COIN

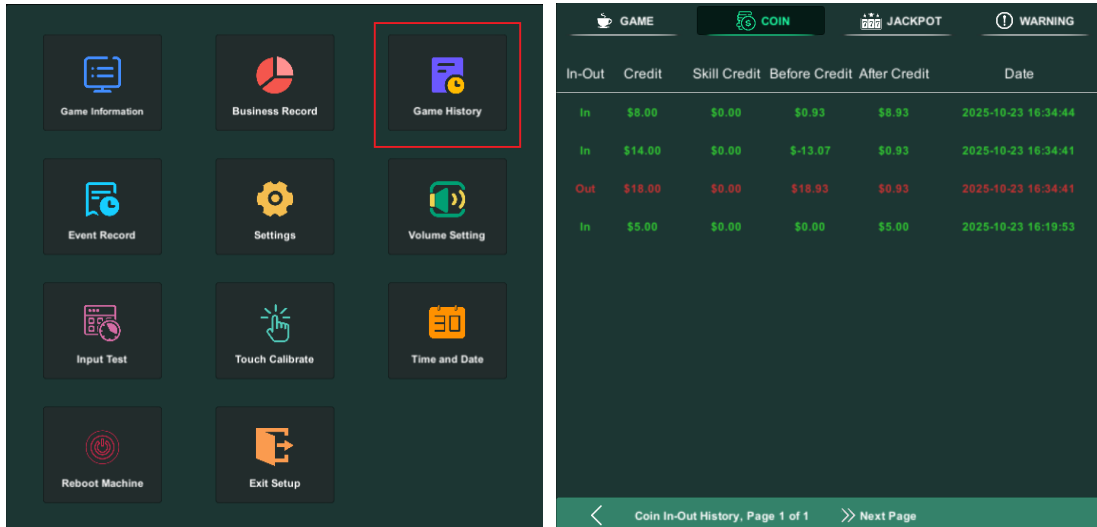

<Figure 8>

<Figure 9>

Coin		
1	In-Out	IN=Credit in, OUT=Credit out
2	Credit	The value of Credit In or Credit Out
3	Skill Credit	The value of Credit In or Credit Out of Skill Game
4	Before Credit	Credit before In/Out
5	After Credit	Credit after In/Out action (AFTER = BEFORE + CREDIT)
6	Date	Time recorded when players Credit in or out
7	<	Click to return to the main back-end page
8	Coin In-Out History,Page 1 of 1	Coin In-Out history, current page No., and total page No.
9	>>Next Page	Go to next page

3) JACKPOT

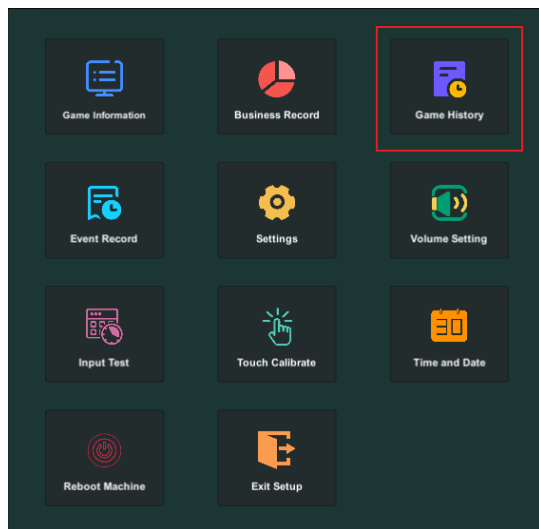

<Figure 10>

A screenshot of the 'JACKPOT' history screen. The screen has a dark green background with a white table. At the top, there are four tabs: 'GAME', 'COIN', 'JACKPOT', and 'WARNING'. The 'JACKPOT' tab is selected. The table has five columns: 'Type', 'Win', 'Before Win', 'After Win', and 'Date'. Below the table, there is a navigation bar with a left arrow, the text 'Jackpot History, Page 1 of 1', and a right arrow labeled 'Next Page'.

Type	Win	Before Win	After Win	Date
MEGA	\$1,462.00	\$2,517.94	\$3,979.94	2025-10-29 14:48:26
MINOR	\$150.00	\$2,251.94	\$2,401.94	2025-10-29 14:47:52
MINI	\$38.00	\$2,206.94	\$2,244.94	2025-10-29 14:47:31
GRAND	\$1,246.00	\$1,005.94	\$2,251.94	2025-10-29 14:47:08

<Figure 11>

Jackpot		
1	Type	Jackpot Type
2	Win	Jackpot Credit won
3	Before Win	Credit before jackpot won
4	After Win	Credit after jackpot won
5	Date	Time recorded when jackpot was won
6	<	Return to the main back-end page
7	Jackpot History, Page 1 of 1	Jackpot history, current page No., and total page No
8	>>Next Page	Go to next page

4) WARNING

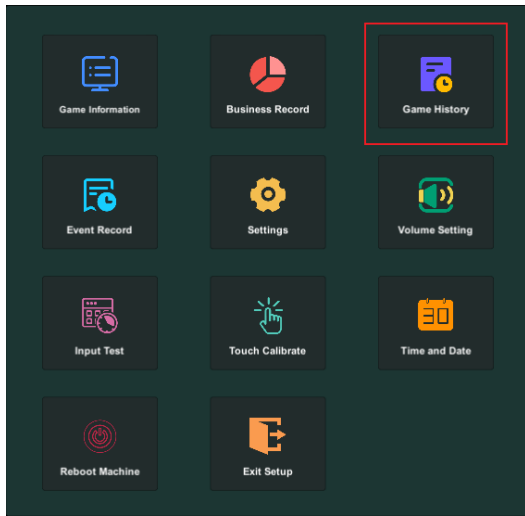

<Figure 12>

A screenshot of the 'WARNING' page, which displays a table of warning history. The table has columns for Play, Win, Limiter, Status, and Date. The status values are 'Pending', 'No Pass', and 'Pass'. The page includes navigation arrows and the text 'Warning History, Page 1 of 1'.

Play	Win	Limiter	Status	Date
\$5.00	\$9.60	\$5.00	Pending	2025-10-29 14:55:05
\$5.00	\$5.40	\$5.00	No Pass	2025-10-29 14:54:37
\$5.00	\$8.00	\$5.00	Pass	2025-10-29 14:54:16

<Figure 13>

A screenshot of the 'WARNING' page, similar to Figure 13, but with a sidebar menu on the left. The sidebar contains a 'Close' button and filter options for 'Pass' and 'No Pass'. The main table shows the same warning history data.

Play	Win	Limiter	Status	Date
\$5.00	\$9.60	\$5.00	Pending	2025-10-29 14:55:05
\$5.00	\$5.40	\$5.00	No Pass	2025-10-29 14:54:37
\$5.00	\$8.00	\$5.00	Pass	2025-10-29 14:54:16

<Figure 14>

A screenshot of the 'Plot O'Gold Game Recall' page. It features a 3x5 grid of symbols including a pickaxe, a character, a helmet, and a 'WILD' symbol. Below the grid, there is a table of game statistics for a specific play.

Plot O'Gold Game Recall 1 of 100	
Game DateTime: 2026-03-30 17:53:25	Total Win: \$6.00
Game Result: Beyond The Limiter	Base Game Win: \$6.00
Credits Before: \$1,912.20	Free Games Win: \$0.00
Credits After: \$1,912.20	Bonus Game Win: \$0.00
Total Bet: \$5.00	Link Game Win: \$0.00
Lines Played: 50	Skill Game Win: \$0.00

<Figure 15>

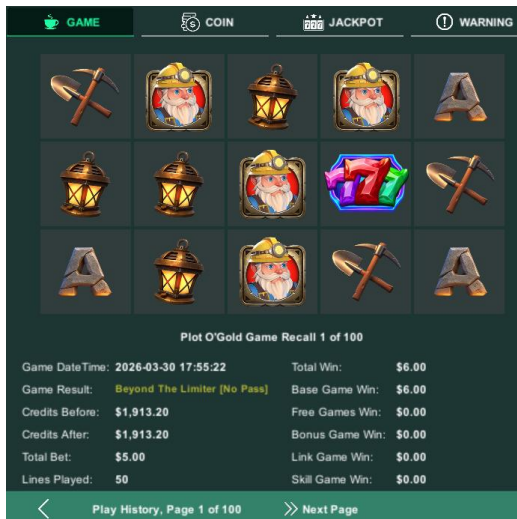

<Figure 16>

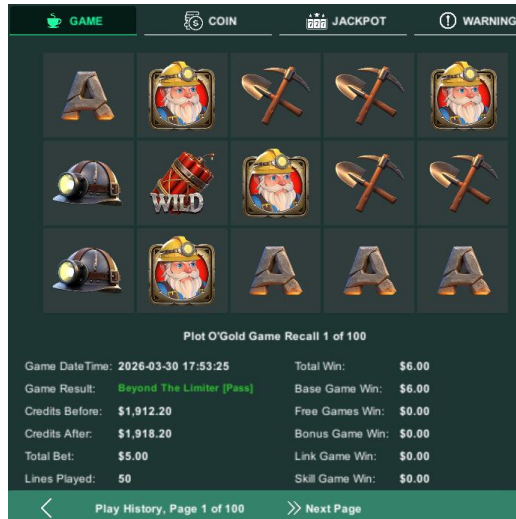

<Figure 17>

Warning		
1	Play	Credit played
2	Win	Credit won
3	Limiter	Winning limit
4	Status	State of the game (PENDING- require validation; PASS-winning was allowed; NO PASS-winning was thrown out) If passed, adding the player's winning points; If not passed, deducting the player's winning points After being set to PASS or NO PASS, it cannot be modified
5	Date	Time recorded of the warning
6	Close	Close
7	Pass	Pass
8	No Pass	No Pass
9	<	Return to the main back-end page
10	Warning History, Page 1 of 1	Warning history, current page No., and total page No.
11	>>Next Page	Go to next page

4. Event Record

1) Enter the back-end and select the **【Event Record】** to view operation records

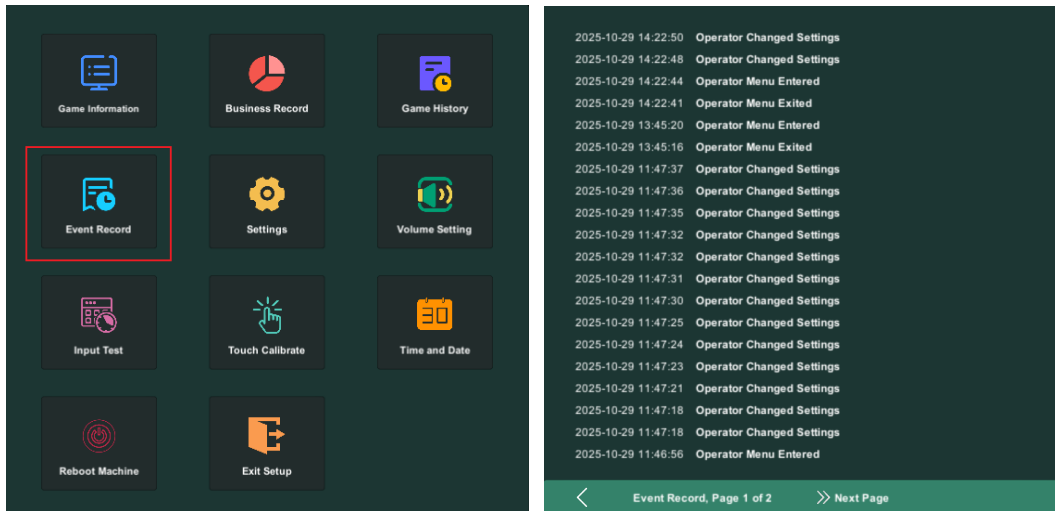

<Figure 18>

<Figure 19>

Event Record		
1	<	Return to the main back-end page
2	Event Record, Page 1 of 2	Current page No., and total page No.
3	>> Next Page	Go to next page

5. Settings

1) Enter the back-end and select **【Settings】** to input the password to view system settings (Initial password: 11111111)

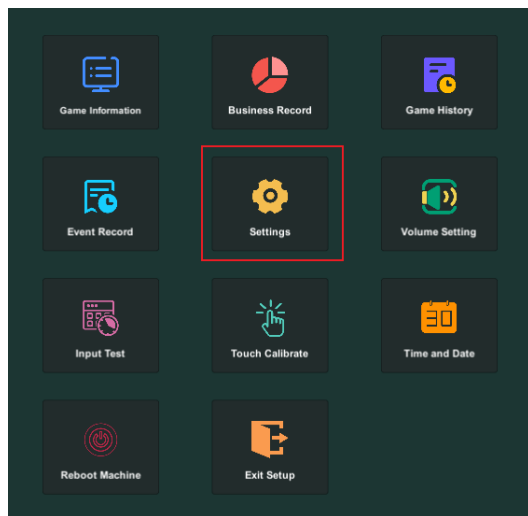

<Figure 20>

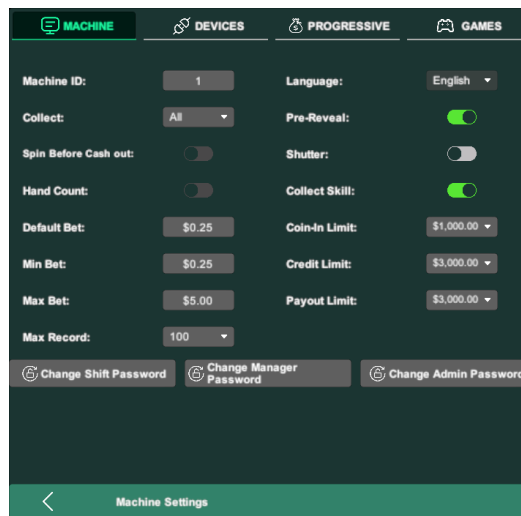

<Figure 21>

SETTING		
1	Machine ID	Machine number. It cannot be duplicated between different devices, which is the prerequisite for normal connection to the JP Server and I-deck
2	Collect	Adjusting the payout mode, the default setting is "ALL", which means all points can be refunded at once. If you choose a specific value, you can only refund the corresponding points once at a time. After playing a game again, you can obtain the right to refund the points again
3	Spin Before Cash out	Redeem setting (Grey=OFF, Highlighted=ON) ON: Need to play one spin to redeem OFF: Can be redeemed consecutively multiple times (Note: It can only be enabled when Collect is not ALL)
4	Hand Count	Hand count display setting ON: the number of times played will be displayed in the game. Points will be redeemed on the basis of the Collect setting and how many hands were played. (Note: It can only be enabled on when Collect is not ALL)
5	Default Bet	Default bet option
6	Min Bet	Min bet option
7	Max Bet	Max bet option

8	Max Record	Maximum number of game reports (Range: 100-500, increasing by 100 each time)
9	Language	Default English (There are no other languages to choose right now)
10	Pre-Reveal	Pre-Reveal feature(Grey=OFF, Highlighted=ON) ON: A PRE-REVEAL button will appear above the SPIN to show the next game points.
11	Shutter	Shutter mode (Grey=OFF, Highlighted=ON) On: Switch to Shutter mode, each column of scrolls will display all icons in sequence, and the STOP button will be disabled
12	Collect Skill	Collect Skill Game (Grey=OFF, Highlighted=ON) On: Triggers a skill game to collect points according to the setting of Collect
13	Coin-in Limit	Coin-in Limit (\$ 500- \$ 1000) When you set a value, the players' coin-in value will not exceed it. If it exceeds, the coin-in door will be closed. If DBA in pulse mode, no coin-in limit
14	Credit Limit	Credit Limit (\$ 3000- \$ 5000) When you set a value, the total credits of players will not exceed it. Once the credit balance is over the limit, the game will be prohibited and points must be redeemed to the restricted range to continue
15	Payout Limit	Payout Limit (\$ 1000- \$ 5000) When you set a value, the value won by the player will not exceed it. Once the value is over the limit, the game will be prohibited and the administrator will have to access the Warning Report in Game History
16	Change shift Password	Change shift Password (Initial password: 11111111) It's only used for data transfer at employee shifts
17	Change Manager Password	Change Manager Password (Initial password: 11111111) It's only used to modify game parameters
18	Change Admin Password	Change Admin Password (Initial password: 11111111) Used to clear operation data and initialize system
19	<	Return to the main back-end page

2) DEVICES

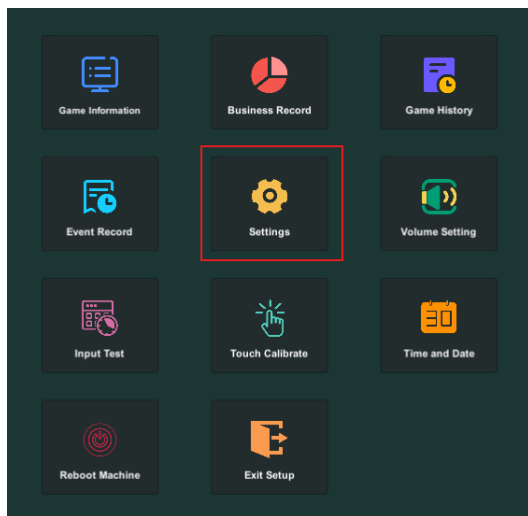

<Figure 22>



<Figure 23>

1	Bill Validator Model	Bill Acceptor model option
2	Printer Model	Printer model option
3	Wire Model	Wire model option
4	In Pulse Rate	In Pulse Rate Left number: signal Right number: the amount of cash in For example, 1:5 means cash in 5 USD, it will output a signal, and the In meters will turn once
5	Out Pulse Rate	Out Pulse Rate Left number: signal Right number: the amount of cash out For example, 1:5 means cash out 5 USD, it will output a signal, and the Out meters will turn once
6	Coin Rate	Rate, 1: 100 means 1 coin is 100 cents; It will be displayed in [Game Information]; Selection can only be made when the Bill Validator Model is Pulse
7	Bills Allowed	The denomination of the player's coin-in, a range of values (\$1-\$5-\$10-\$20-\$50-\$100) Reject means to close this channel

8	Display Credits as	<p>Setting of US dollar and Credits to display the value</p> <p>Money>The value on the game will display a symbol (\$), (JP Server+game back-end+public UI + other related values)</p> <p>Points>The value will display in the form of credits, (JP Server+game back-end+public UI + other related values)</p>
9	Network	<p>Settings for STATIC and DHCP IP (Grey=STATIC IP, Highlighted=DHCP IP)</p> <p>Note: If set to DHCP, it is necessary to connect to a router network with open DHCP services through a network cable</p>
10	Link Jackpot	<p>Connecting to the JP server(Grey=OFF, Highlighted=ON)</p> <p>After opening, it will automatically find and connect to the JP server</p>
11	Buttons	Buttons (Grey=OFF, Highlighted=ON)
12	Flip Screen	Press to rotate the game page display 180 degrees
13	Change Receipt Template	Print receipt details: Such as [Location name, address, phone number, fax number, game name, display credits as, remarks]
14	Reset Machine to Factory Settings	System initialization, clear all game data (Need to enter administrator password)



<Figure 24>

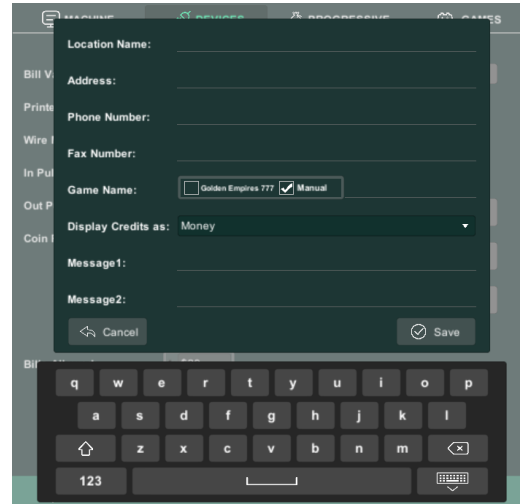

<Figure 25>

1	Location Name	Location Name
2	Address	Address
3	Phone Number	Phone Number
4	Fax Number	Fax Number
5	Game Name	Game Name (Blazing Link: Default game name, MANUAL: Custom Game Name)
6	Display Credits as	Print US dollars or Credits
7	Message1	Message1
8	Message2	Message2
9	Cancel	After clicking, the parameter will not be saved and will return to the previous menu
10	Save	After clicking, the parameter will be saved and will return to the previous menu

3) PROGRESSIVE

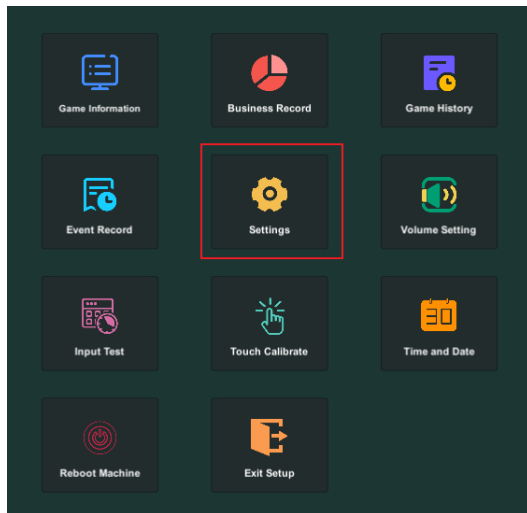

<Figure 26>

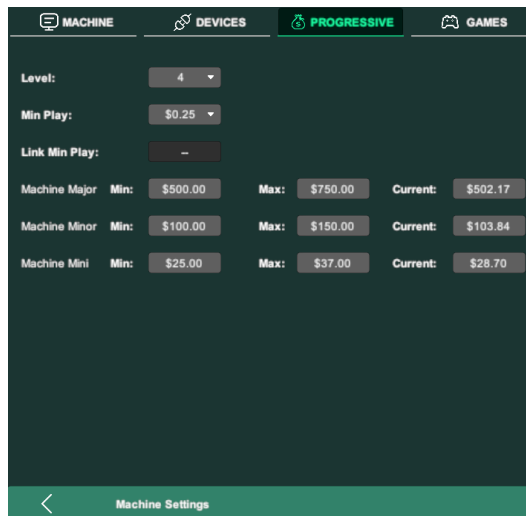

<Figure 27>

LOCAL JACKPOT	<p>LEVEL=Jackpot Contribution rate. Level 1 the progressive grows the slowest. Level 8 the progressive grows the fastest.</p> <p>Min Play=Minimum bet to win Local Jackpot, with options (\$ 0.25-\$ 0.5-\$ 0.75-\$ 1.00)</p> <p>Link Min Play=Minimum bet to win community jackpot, can only be read but not changed. To change, go to Jackpot Server back-end</p> <p>Machine MAJOR: MIN = base value (\$300.00 to \$450.00, default is \$300.00).</p> <p>MAX=Maximum value (1.5~10 times the current value of MIN, default is MIN*1.5);</p> <p>Machine MINOR: MIN=base value (\$100.00~\$150.00, default is \$100.00)</p> <p>MAX=maximum value (1.5~10 times the current value of MIN, default is MIN*1.5);</p> <p>Machine MINI: MIN=base value (\$25.00~\$100.00, default is \$25.00)</p> <p>MAX=maximum value (1.5~10 times the current value of MIN, default is MIN*1.5);</p> <p>Current: initial value of the lottery: any value of Min-Max can be set, if set to *, then the final value of the lottery is between * and Max</p>
---------------	---

4) GAMES

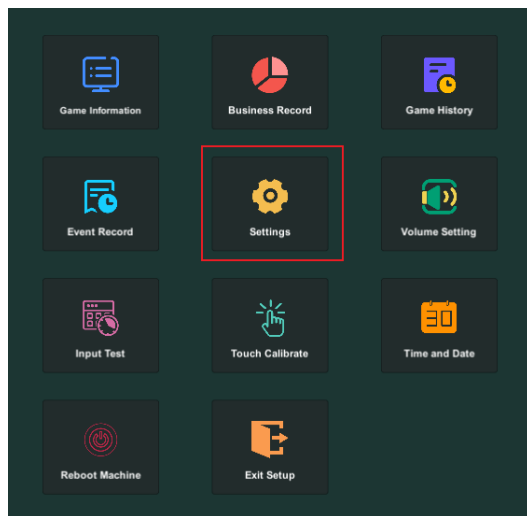

<Figure 28>

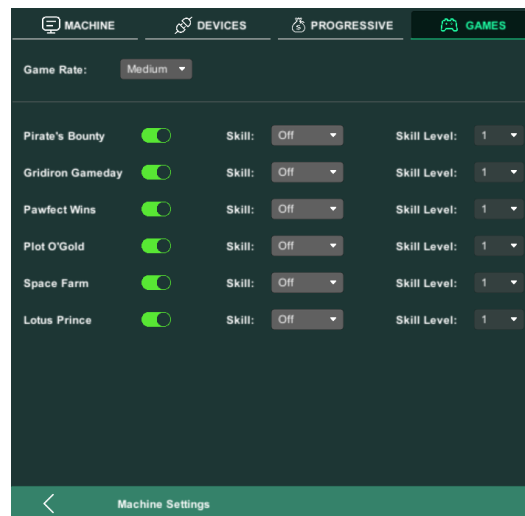

<Figure 29>

1	Game Rate	<p>Game Rate (the default game rate is medium) Adjustable: [Very Low / Low / Medium / High]</p> <p>Very Low: Game Rate is about 86%; Low: Game Rate is about 89%; Medium: Game Rate is about 92%; High: Game Rate is about 95%;</p> <p>The larger the percentage, the lower the difficulty</p>
2	Pirate's Bounty	<p>Left switch: (Grey=OFF, Highlighted=ON) If you choose ON, the game card in the lobby will be highlighted, and you can play the game</p> <p>If you choose OFF, the game cards in the lobby are grayed out, you cannot play the game</p> <p>Skill: Skill game. When the winning points in one game is less than the betting points, the skill game will available to play if the player chooses..</p> <p>If the game wins, there will be an additional reward: (Play-Win) * 1.1</p> <p>Skill currently has two types of skill games: Stick Ball/Match Up. When Off is selected, the skill game will not be triggered.</p> <p>Skill Level: the difficulty level of skill games, which can be adjusted to different levels. The higher the value set, the greater the difficulty</p> <p>Stick Ball is fixed at 1, Match Up has 1, 2, 3 levels (default is 1)</p>
3	Gridiron Gameday	
4	Pawfect Wins	
5	Plot O' Gold	
6	Space Farm	
7	Lotus Prince	

6. Volume Setting

1) Select **【Volume Setting】** to set the volume

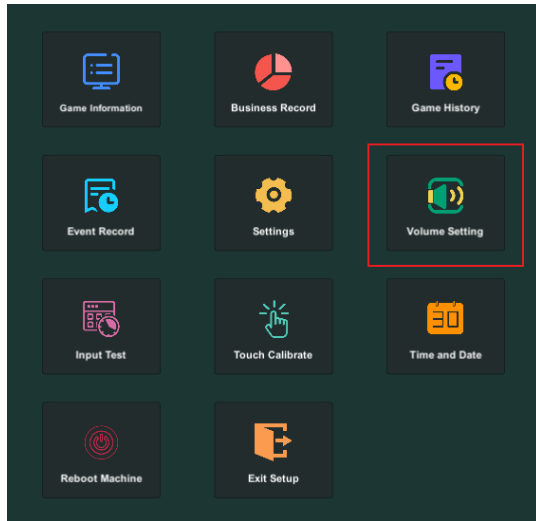

<Figure 30>

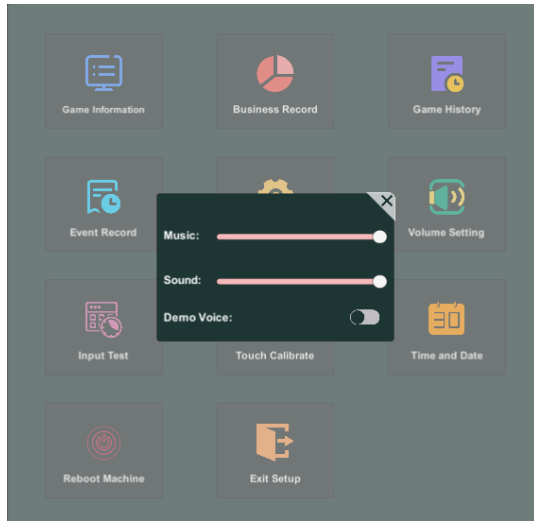

<Figure 31>

Volume Setting		
1	VOLUME	<p>Volume control (Music and Sound)</p> <p>Demo Voice: A highlighted state (ON) indicates that there is sound in the game during demo mode The gray state (OFF) indicates that there is no sound in the game during demo mode</p>

7. Input Test

1) Enter the back-end and select the **【Input Test】** to test input button

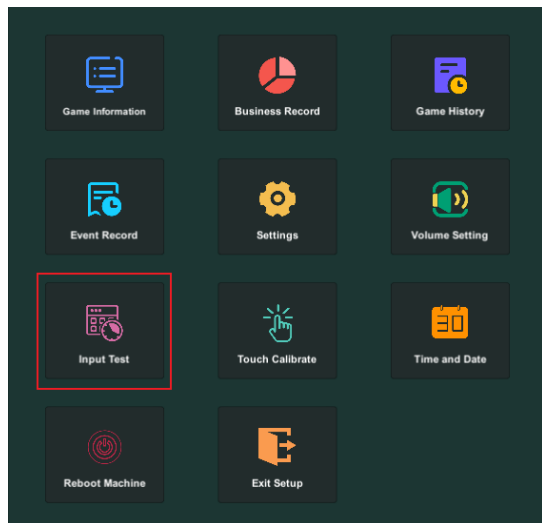

<Figure 32>

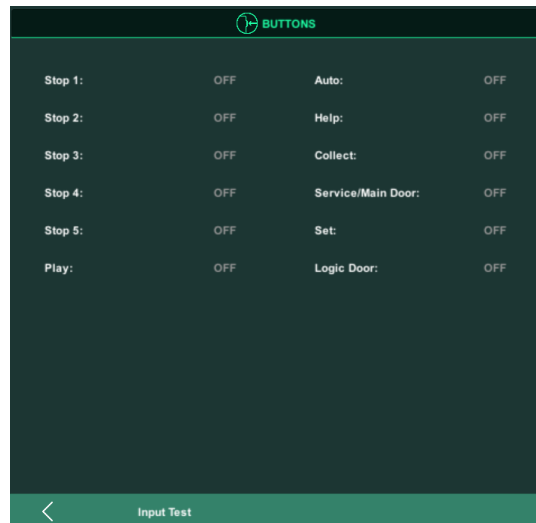

<Figure 33>

Input Test

1	BUTTONS	There are 12 buttons can be tested. In the initial state, the grey font "OFF" is displayed to the right of the button, indicating that the button has not been pressed or turned on. Press the corresponding button, and if it works properly, the green font "ON" will be displayed on the right side of the corresponding button. As shown in<Figure 33>
---	---------	--

8. Touch Calibrate

1) Enter the back-end and select **【Touch Calibrate】** to check touch calibration

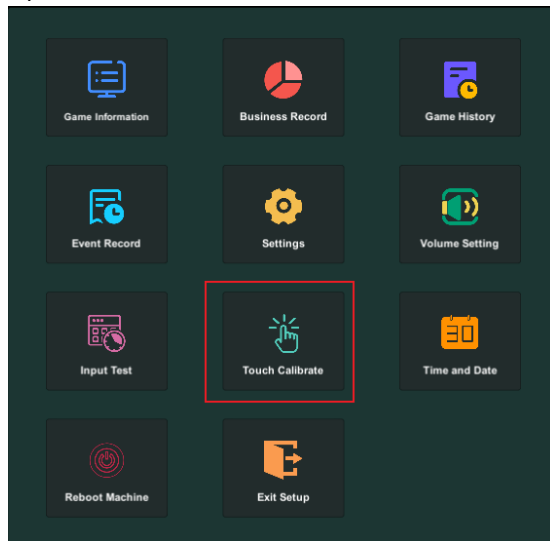

<Figure 34>

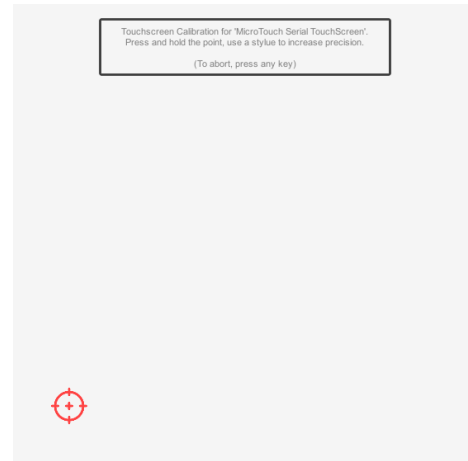

<Figure 35>

Touch Calibrate		
1	Touch Calibrate	<p>Used as an auxiliary setting for re-calibrating the touch screen when touching an inaccurate position on the screen. As shown in <Figure 34> and <Figure 35>, following the prompts on the screen (Touchscreen Calibration for 'Micro Touch Serial Touchscreen'. Press and hold the point, use a stylus to increase precision, (To abort, press any key))</p> <p>Firstly, find the red aiming symbol in the lower left corner and hold it for 3 seconds. Then, find the red aiming symbol in the upper right corner and hold it for 3 seconds. The calibration will be completed and the system will be automatically returned to the previous menu</p>

9. Time and Date

1) Enter the back-end and select **【Time and Date】** to set the time and date

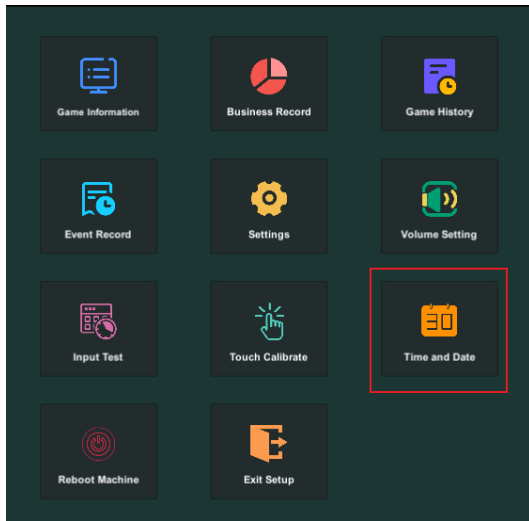

<Figure 36>

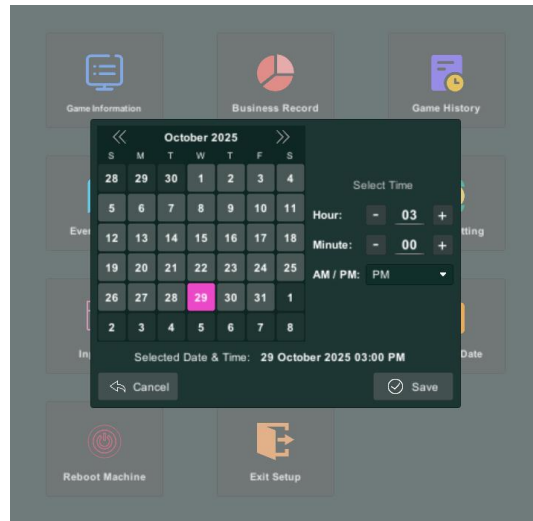

<Figure 37>

Time and Date		
1	Hour	Hour
2	Minute	Minute
3	AM/PM	AM/PM
4	Selected Date & Time	Selected Date & Time
5	Cancel	Cancel
6	Save	Save

10. Reboot Machine

1) Enter the back-end and selecting **【Reboot Machine】** will restart the game

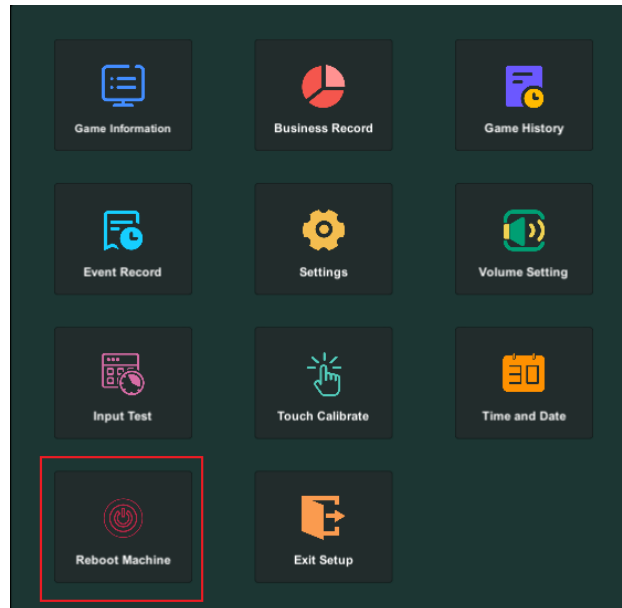

<Figure 38>

11. Exit Setup

1) Select **【Exit Setup】** to exit and return to regular game mode

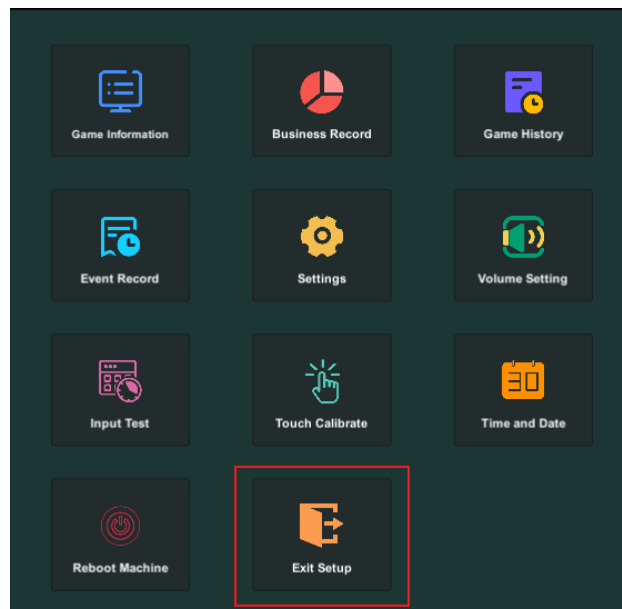

<Figure 39>

12. Connection Diagram Of JP Sever

Jackpot Linking Diagram

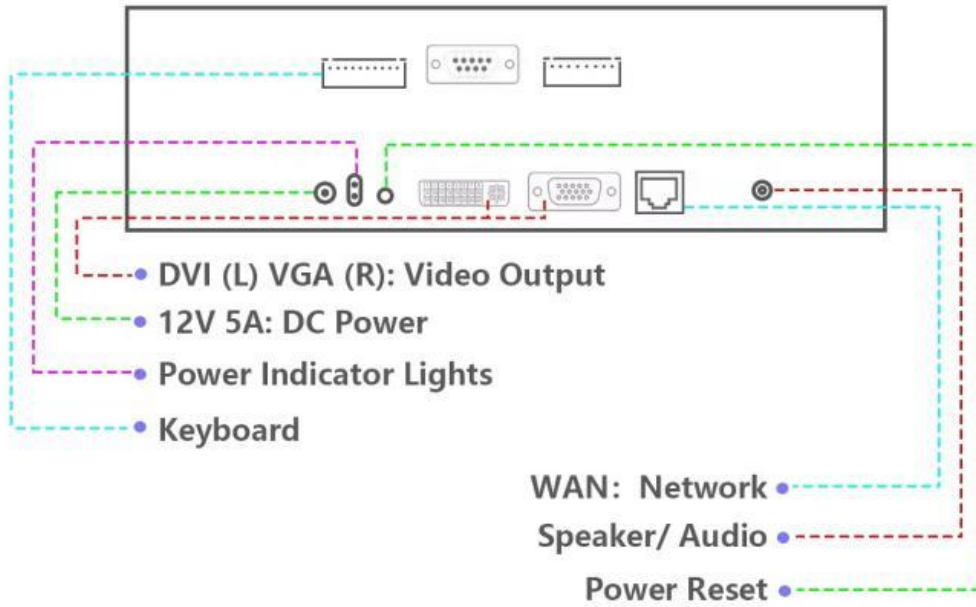

13. Connection Diagram Of Blazing Link

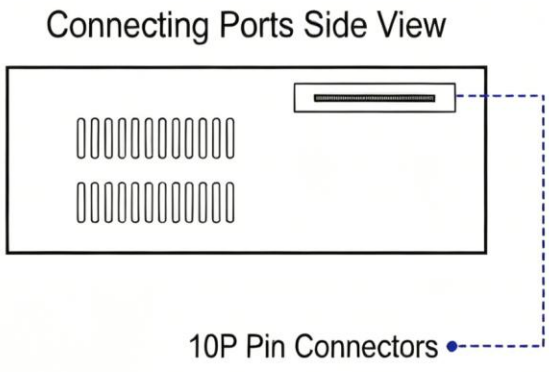
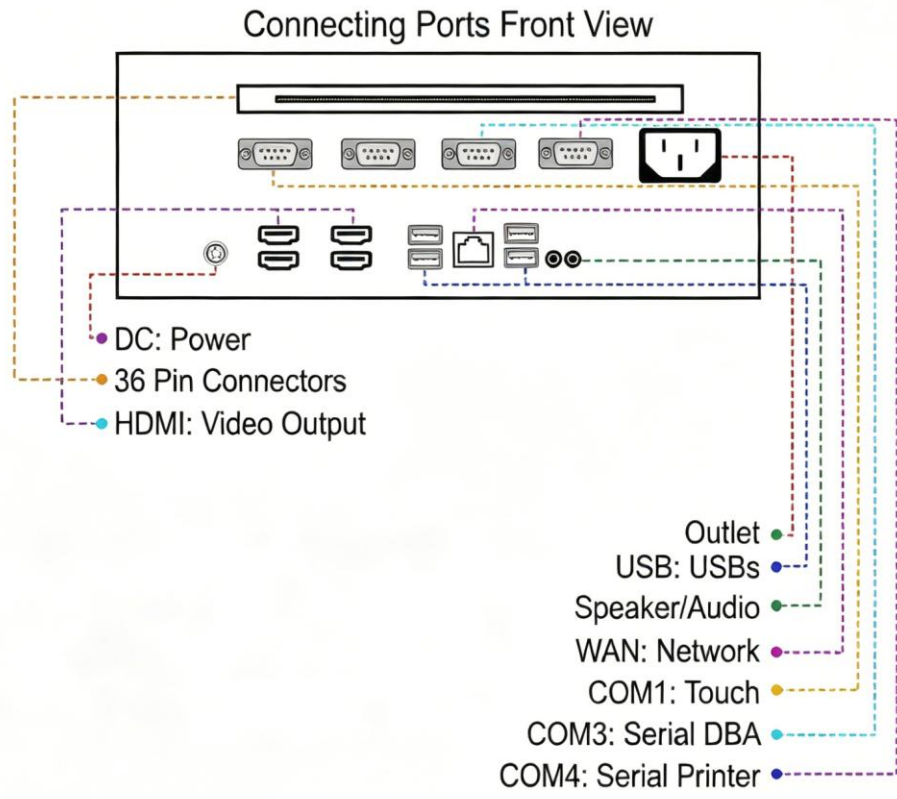







Pin out Connection Diagram For Blazing Link

Connection Diagram For Blazing Link

JENKA LAB WIRE TYPE		
36Pins		
PARTS SIDE		SOLDER SIDE
	1	
SPEAKER_R +	2	SPEAKER_R -
SPEAKER_L +	3	SPEAKER_L -
	4	SPEAKER_L -
	5	
	6	
	7	
	8	
	9	
	10	PLAY BUTTON
	11	
	12	SPEAKER_L +
	13	
	14	LOGIC DOOR SW
	15	MAIN DOOR SW
	16	TICKET LAMP
	17	
PULSE BILL IN	18	
	19	
CLERK MENU SW	20	ADMIN MENU SW
	21	TICKET BUTTON
	22	
METER TOTAL IN	23	
	24	DISCONNECT
	25	
	26	DISCONNECT
	27	DISCONNECT
METER TOTAL OUT	28	
	29	
	30	
	31	PLAY LAMP
	32	
	33	
	34	
	35	DISCONNECT
	36	

JENKA LAB WIRE TYPE		
10 Pins		
PARTS SIDE		SOLDER SIDE
GROUND	1	GROUND
GROUND	2	GROUND
+5V	3	+5V
+5V	4	+5V
+12V	5	+12V
+12V	6	+12V
	7	
	8	
GROUND	9	GROUND
GROUND	10	GROUND

14. Warning Prompts

Explanation		
Icon	Tips	Solution
	Bill acceptor format error	Recheck the pulse or serial port
	Printer format error	Recheck the pulse or serial port
	Credit in exceeded the limit	Redeem below the limit credits or setting a higher limit credits in the back-end
	Total credit out of limit	Redeem below the limit credits or setting a higher limit credits in the back-end
	Winning credit exceeded the limit	Select PASS / NO PASS buttons in the 【WARNING RECORD】
	Linked jackpot is not connected	Connect to linked jackpot server board