

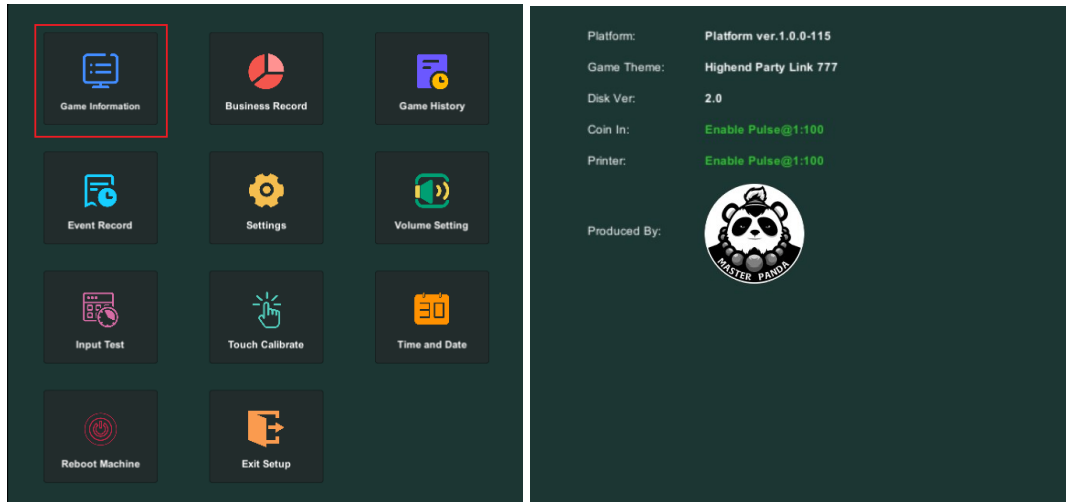

Table of Contents

1. Game Information.....	1
2. Business Record.....	2
3. Game History.....	4
4. Event Record.....	9
5. Settings.....	10
6. Volume Setting.....	17
7. Input Test.....	18
8. Touch Calibrate.....	19
9. Time and Date.....	20
10. Reboot Machine.....	21
11. Exit Setup.....	21
12. Connection Diagram Of JP Sever.....	22
13. Connection Diagram Of Highand Party link II.....	23
14. Warning Prompts.....	25

# 1. Game Information

1) After the device is turned on, enter the back-end and select **【Game Information】** to view game information



Game Information		
1	Platform	Platform Version Number
2	Game Theme	High End Party Link 777
3	Disk Ver	32 bit system display 1.0; 64 bit system display 2.0
4	Coin In	(Enable Pulse@1:100) Indicates that 1 coin is 100 points
5	Printer	(Enable Pulse@1:100) Indicates that 1 coin redeemed is 100 points
6	Produced By	Manufacturer
7	<	Click it to go back to the main page of back-end

<Figure 1>

<Figure 2>

## 2. Business Record

1) Enter the back-end and select **【Business Record】** to view business records

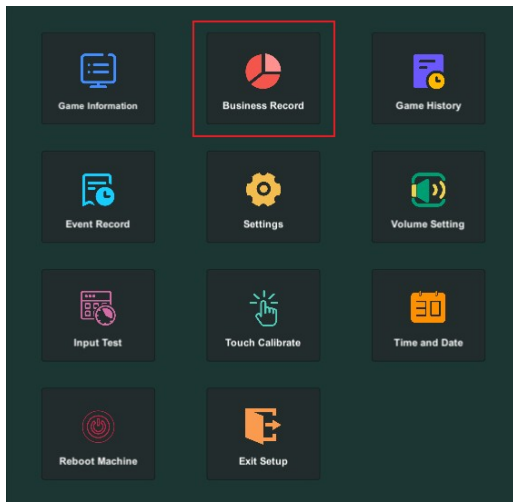

<Figure 3>

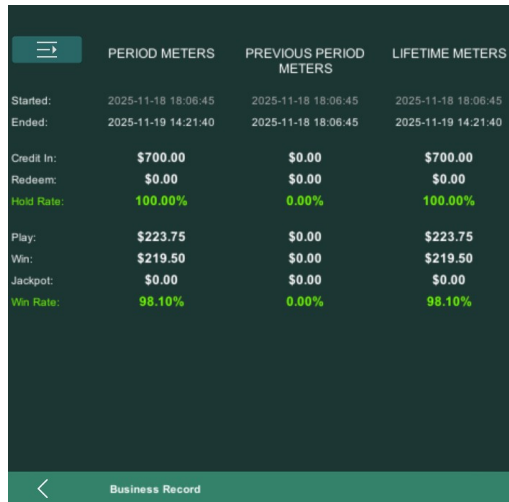

<Figure 4>

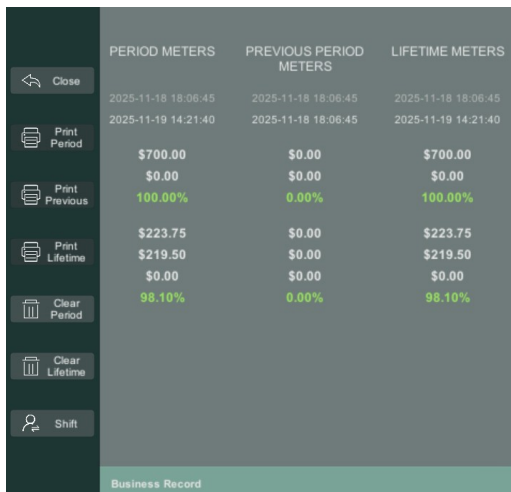

<Figure 5>

Business Record		
1	PERIOD METERS	Data of the current period meters
2	PREVIOUS PERIOD METERS	Data of the previous period meters
3	LIFETIME METERS	The sum of all period meters

4	Started	Start Time
5	Ended	End Time
6	Credit In	Data of Credit In
7	Redeem	Data of Credit Out
8	Hold Rate	<p>PERIOD METERS&gt;  Current period meters (Credit In - Credit Out) /Credit In</p> <p>PREVIOUS PERIOD METERS&gt;  Previous period meters (Credit In - Credit Out) / Credit In</p> <p>LIFETIME METERS&gt;  All Period meters (Credit In - Credit Out) / Credit In</p>
9	Play	Credit played
10	Win	Credit won from other than Jackpot
11	Jackpot	Credit won from Jackpot
12	Win Rate	<p>PERIOD METERS&gt;  Current period meters (WIN+JACKPOT)/PLAY</p> <p>PREVIOUS PERIOD METERS&gt;  Previous period meters (WIN+JACKPOT)/PLAY</p> <p>LIFETIME METERS&gt;  All period meters (WIN+JACKPOT)/PLAY</p>
13		Click it to enter the setting page
14	Close	Close the settings page and return to the business records page
15	Print Period	Print all data for the current period meters
16	Print Previous	Print all data for the previous period meters
17	Print Lifetime	Print all data for all period meters
18	Clear Period	Clear all data for the current period meters
19	Clear Lifetime	Clear all data for all period meters

20	Shift	Submitting the date of current period meters to the previous period meters, requires administrator password (Initial Password: 11111111)
21	<	Return to the main back-end page

### 3. Game History

1) Enter the back-end and select **【Game History】** to view game history

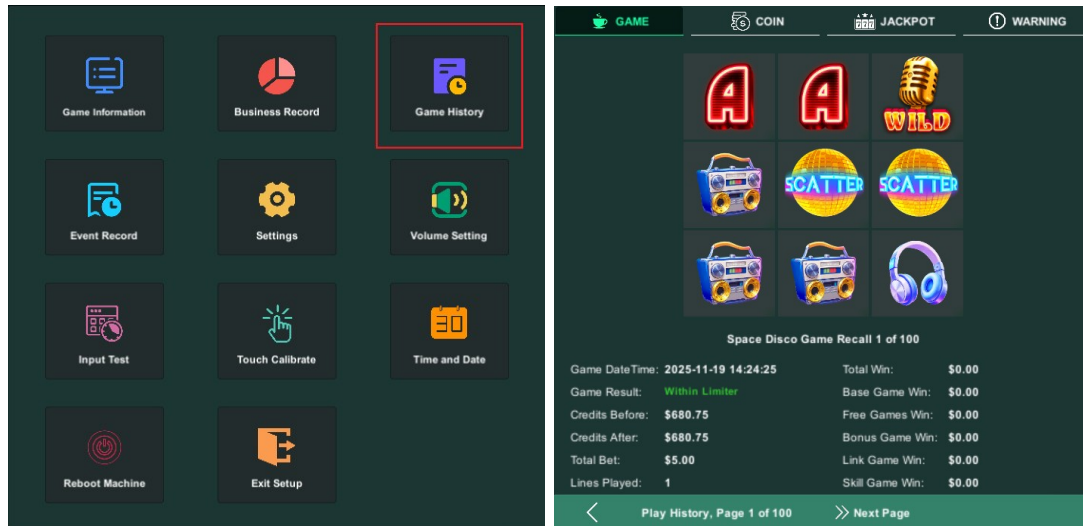

<Figure 6>

<Figure 7>

Game History		
1	Space Disco Game Recall 1 of 100	Game name+current page No.+ total page No.
2	Game Date Time	The start time of the game
3	Game Result	Game Result
4	Credits Before	Credits before game
5	Credits After	Credits after game
6	Total Bet	Total Bet
7	Lines played	Lines Played
8	Total Win	Total Win
9	Base Game Win	Won in regular game

10	Free Games Win	Won in Free game
11	Bonus Game Win	Won in Bonus game
12	Link Game Win	Won in Link Bonus
13	Skill Game Win	Won in skill game
14	<	Click it to return to the main back-end page
15	Play History Page 1 of 100	Play history, current page No., and total page No.
16	>>Next Page	Go to next page

## 2 ) COIN

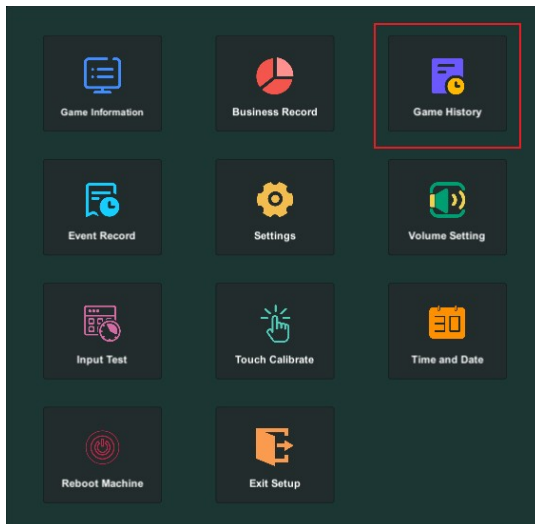

<Figure 8>

The image shows the 'COIN' history page with a table of transactions. The table has columns for In-Out, Credit, Skill Credit, Before Credit, After Credit, and Date. The data is as follows:

In-Out	Credit	Skill Credit	Before Credit	After Credit	Date
Out	\$50.00	\$0.00	\$680.75	\$630.75	2025-11-19 14:25:40
In	\$600.00	\$0.00	\$100.00	\$700.00	2025-11-19 14:20:31
In	\$100.00	\$0.00	\$0.00	\$100.00	2025-11-19 09:00:07

At the bottom of the screen, there is a navigation bar with a left arrow, the text 'Coin In-Out History, Page 1 of 1', and a right arrow labeled 'Next Page'.

<Figure 9>

Coin		
1	In-Out	IN=Credit in, OUT=Credit out
2	Credit	The value of Credit In or Credit Out
3	Skill Credit	The value of Credit In or Credit Out of Skill Game
4	Before Credit	Credit before In/Out
5	After Credit	Credit after In/Out action (AFTER = BEFORE + CREDIT)
6	Date	Time recorded when players Credit in or out

7	<	Click to return to the main back-end page
8	Coin In-Out History, Page 1 of 100	Coin In-Out history, current page No., and total page No.
9	>>Next Page	Go to next page

### 3 ) JACKPOT

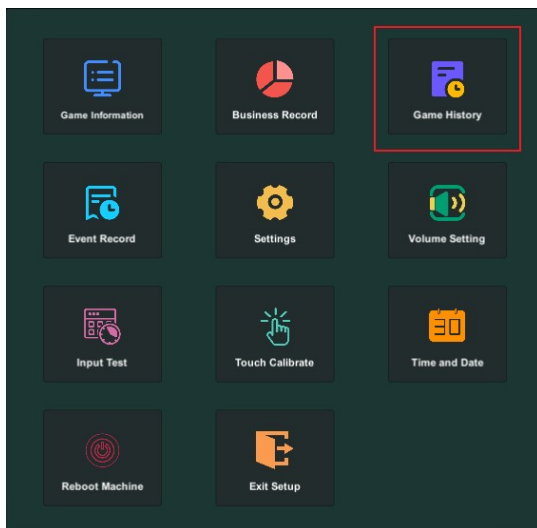

<Figure 10>

Type	Win	Before Win	After Win	Date
MAJOR	\$455.00	\$2,864.75	\$3,319.75	2025-11-19 14:34:04
MINOR	\$155.00	\$2,709.75	\$2,864.75	2025-11-19 14:33:59
MINI	\$40.00	\$2,674.75	\$2,714.75	2025-11-19 14:33:53
GRAND	\$1,284.00	\$1,400.75	\$2,684.75	2025-11-19 14:32:49
MEGA	\$800.00	\$840.75	\$1,640.75	2025-11-19 14:31:32

<Figure 11>

Jackpot		
1	Type	Jackpot Type: Mini, Minor and Major
2	Win	Jackpot Credit won
3	Before Win	Credit before jackpot won
4	After Win	Credit after jackpot won (AFTER = BEFORE +WIN)
5	Date	Time recorded when jackpot was won
6	<	Return to the main back-end page

7	Jackpot History,Page 1 of 100	Jackpot history, current page No., and total page No
8	>>Next Page	Go to next page

## 4 ) WARNING

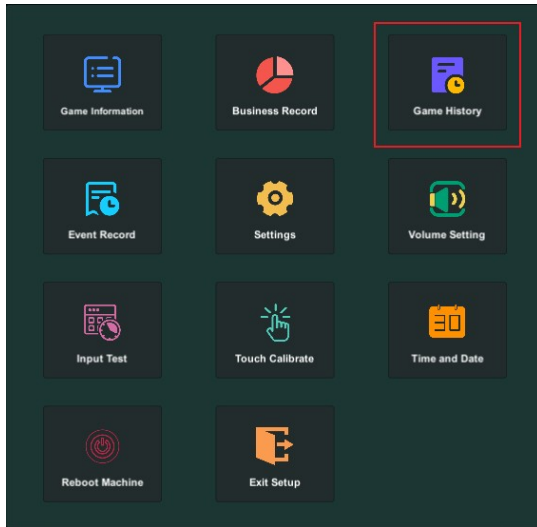

<Figure 12>

A screenshot of the 'WARNING' section in the game interface. It features a table with columns for Play, Win, Limiter, Status, and Date. The table contains three rows of data. Below the table, there are navigation arrows and the text 'Warning History, Page 1 of 1'.

Play	Win	Limiter	Status	Date
\$5.00	\$10.00	\$5.00	Pending	2025-11-19 15:11:31
\$5.00	\$75.00	\$5.00	No Pass	2025-11-19 15:10:50
\$5.00	\$50.00	\$5.00	Pass	2025-11-19 15:09:44

<Figure 13>

A screenshot of the 'WARNING' section, similar to Figure 13, but with a sidebar menu on the left. The sidebar contains a 'Close' button and three filter options: 'Pass', 'No Pass', and 'No Pass'. The table data is the same as in Figure 13.

Play	Win	Limiter	Status	Date
\$5.00	\$10.00	\$5.00	Pending	2025-11-19 15:11:31
\$5.00	\$75.00	\$5.00	No Pass	2025-11-19 15:10:50
\$5.00	\$50.00	\$5.00	Pass	2025-11-19 15:09:44

<Figure 14>

A screenshot of the 'Space Disco Game Recall' screen. It displays a 3x3 grid of symbols: a green alien head, a pink 'K', a blue 'J', a blue 'J', a blue 'J', and a gold 'BONUS' symbol. Below the grid, the text 'Space Disco Game Recall 1 of 100' is shown. A table of game statistics follows, including Game DateTime, Game Result, Credits Before/After, Total Bet, Lines Played, Total Win, Base Game Win, Free Games Win, Bonus Game Win, Link Game Win, and Skill Game Win.

Space Disco Game Recall 1 of 100	
Game DateTime: 2025-11-19 15:11:31	Total Win: \$10.00
Game Result: <b>Beyond The Limiter</b>	Base Game Win: \$10.00
Credits Before: \$1,458.50	Free Games Win: \$0.00
Credits After: \$1,458.50	Bonus Game Win: \$0.00
Total Bet: \$5.00	Link Game Win: \$0.00
Lines Played: 1	Skill Game Win: \$0.00

<Figure 15>

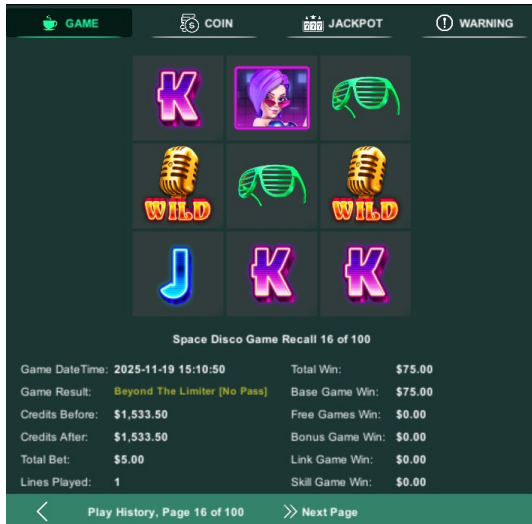

<Figure 16>

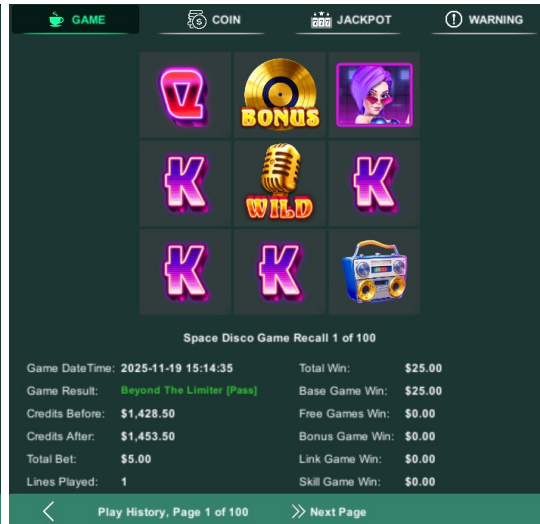

<Figure 17>

Warning		
1	Play	Credit played
2	Win	Credit won ;
3	Limiter	Winning limit
4	Status	State of the game (PENDING- require validation; PASS-winning was allowed; NO PASS-winning was thrown out)  If passed, adding the player's winning points; If not passed, deducting the player's winning points
5	Date	Time recorded of the warning
6	Close	Close
7	Pass	Pass
8	No Pass	No Pass
9	<	Return to the main back-end page
10	Warning History,Page 1 of 100	Warning history, current page No., and total page No.
11	>>Next Page	Go to next page

## 4. Event Record

1) Enter the back-end and select the **Event Record** to view operation records

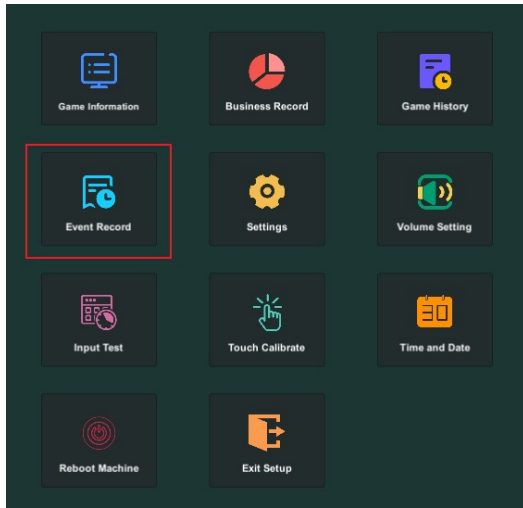

<Figure 18>

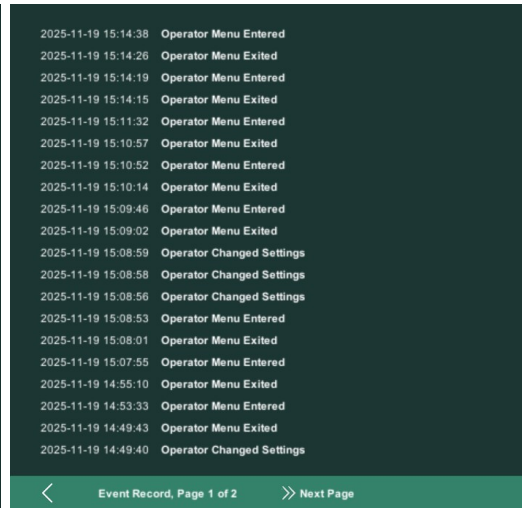

<Figure 19>

Event Record		
1	<	Return to the main back-end page ;
2	Event Record, Page 1 of 2	Current page No., and total page No.
3	>> Next Page	Go to next page

## 5. Settings

1) Enter the back-end and select **【Settings】** to input the password to view system settings (Initial password: 11111111)

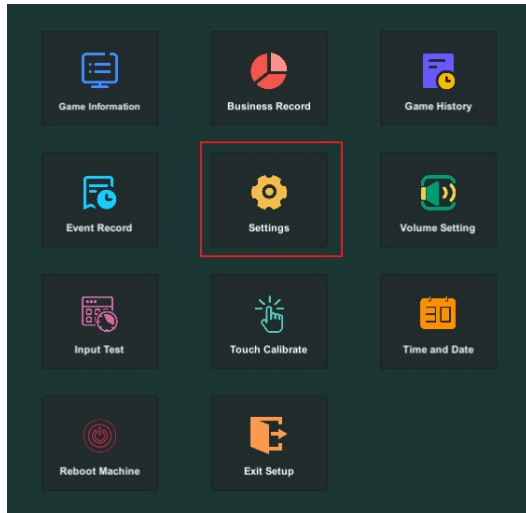

<Figure 20>

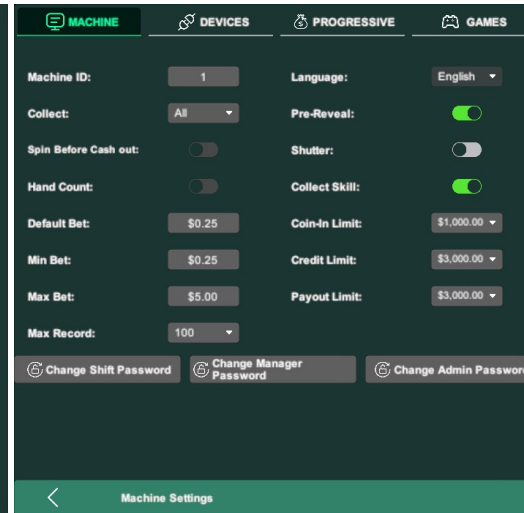

<Figure 21>

SETTING		
1	Machine ID	Machine number. It cannot be duplicated between different devices, which is the prerequisite for normal connection to the JP Server and I-deck
2	Collect	Adjusting the payout mode, the default setting is "ALL", which means all points can be refunded at once. If you choose a specific value, you can only refund the corresponding points once at a time. After playing a game again, you can obtain the right to refund the points again
3	Spin Before Cash out	Redeem setting (Grey=OFF, Highlighted=ON) ON: Need play one spin to redeem OFF: Can be redeemed consecutively multiple times  (Note: It can only be enabled when Collect is not ALL)
4	Hand Count	Hand count display setting  ON: the number of games played will be displayed in the game. Points will be redeemed on the basis of the Collect setting and how many hands were played.  (Note: It can only be enabled on when Collect is not ALL)
5	Default Bet	Default bet option
6	Min Bet	Min bet option

7	Max Bet	Max bet option
8	Max Record	Maximum number of game reports (Range: 100-500, increasing by 100 each time)
9	Language	Default English (There are no other languages to choose right now)
10	Pre-Reveal	Pre-Reveal feature(Grey=OFF, Highlighted=ON)  ON: A PRE-REVEAL button will appear above the SPIN to show the next game results.
11	Shutter	Shutter mode (Grey=OFF, Highlighted=ON)  On: Switch to Shutter mode, each column of scrolls will display all icons in sequence, and the STOP button will be disabled
12	Collect Skill	Collect Skill Game (Grey=OFF, Highlighted=ON)  On: Triggers a skill game to collect points according to the setting of Collect
13	Coin-in Limit	Coin-in Limit ( \$ 500- \$ 1000 )  When you set a value, the players' coin-in value will not exceed it. If it exceeds, the coin-in door will be closed. If DBA in pulse mode, no coin-in limit
14	Credit Limit	Credit Limit ( \$ 3000- \$ 5000 )  When you set a value, the total credits of players will not exceed it. Once the credit balance is over the limit, the game will be prohibited and points must be redeemed to the restricted range to continue
15	Payout Limit	Payout Limit ( \$ 1000- \$ 5000 )  When you set a value, the value won by the player will not exceed it. Once the value is over the limit, the game will be prohibited and the administrator will have to access the Warning Report in Game History
16	Change shift Password	Change shift Password (Initial password: 11111111)  For data transfer at employee shifts

17	Change Manager Password	Change Manager Password (Initial password: 11111111) To modify game parameters
18	Change Admin Password	Change Admin Password (Initial password: 11111111) To clear operation data and initialize system
19	<	Return to the main back-end page

## 2) DEVICES

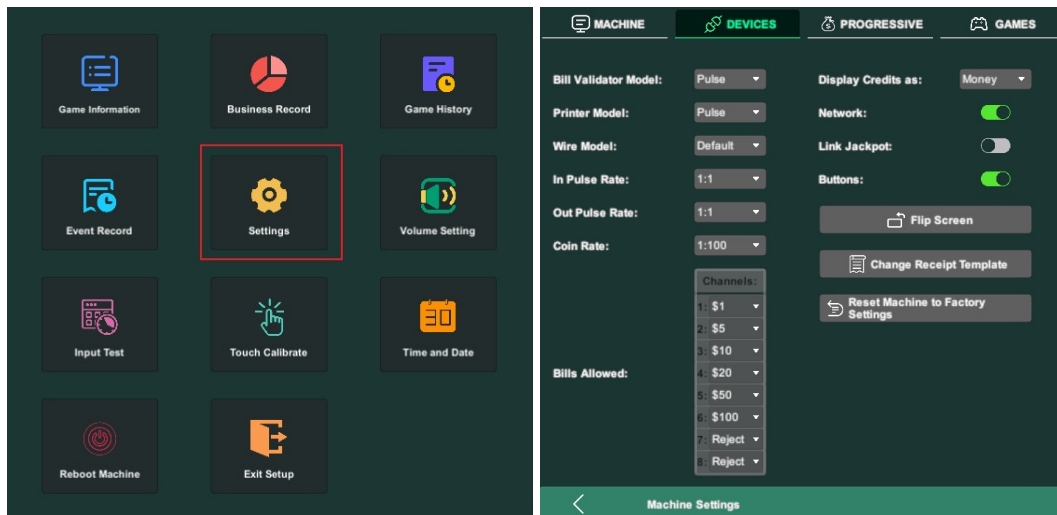

<Figure 22>

<Figure 23>

1	Bill Validator Model	Bill Acceptor model option
2	Printer Model	Printer model option
3	Wire Model	Wire model option
4	In Pulse Rate	In Pulse Rate Left number: signal Right number: the amount of cash in  For example, 1:5 means cash in 5 USD, it will output a signal, and the In meters will turn once
5	Out Pulse Rate	Out Pulse Rate Left number: signal Right number: the amount of cash out  For example, 1:5 means cash out 5 USD, it will output a

		signal, and the Out meters will turn once
6	Coin Rate	Rate, 1: 100 means 1 coin is 100 cents; It will be displayed in [Game Information]; Selection can only be made when the Bill Validator Model is <b>Pulse</b>
7	Bills Allowed	The denomination of the player's coin-in, a range of values (\$1-\$5-\$10-\$20-\$50-\$100) Reject means to close this channel
8	Display Credits as	Setting of US dollar and Credits to display the value  Money>The value on the game will display a symbol (\$), (JP Server+game back-end+public UI + other related values)  Points>The value will display in the form of credits, (JP Server+game back-end+public UI + other related values)
9	Network	Settings for STATIC and DHCP IP (Grey=STATIC IP, Highlighted=DHCP IP)  Note: If set to DHCP, it is necessary to connect to a router network with open DHCP services through a network cable
10	Link Jackpot	Connecting to the JP server (Grey=OFF, Highlighted=ON)  After booting, it will automatically find and connect to the JP server
11	Buttons	Buttons (Grey=OFF, Highlighted=ON)
12	Flip Screen	Press to rotate the game page display 180 degrees
13	Change Receipt Template	Print receipt details: Such as [Location name, address, phone number, fax number, game name, display credits as, remarks]
14	Reset Machine to Factory Settings	System initialization, clear all game data (Need to enter administrator password)



<Figure 24>

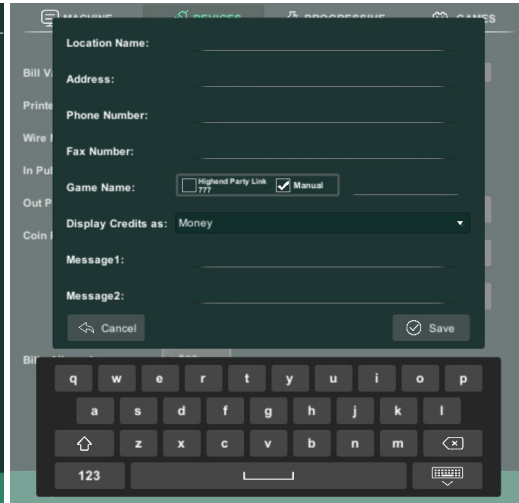

<Figure 25>

1	Location Name	Location Name
2	Address	Address
3	Phone Number	Phone Number
4	Fax Number	Fax Number
5	Game Name	Game Name (High End Party 777: Default game name, MANUAL: Custom Game Name)
6	Display Credits as	Print US dollars or Credits
7	Message1	Message1
8	Message2	Message2
9	Cancel	After clicking, the parameter will not be saved and will return to the previous menu
10	Save	After clicking, the parameter will be saved and will return to the previous menu

### 3) PROGRESSIVE

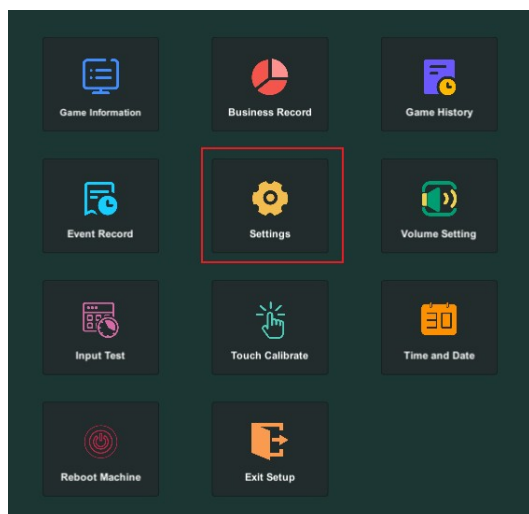

<Figure 26>

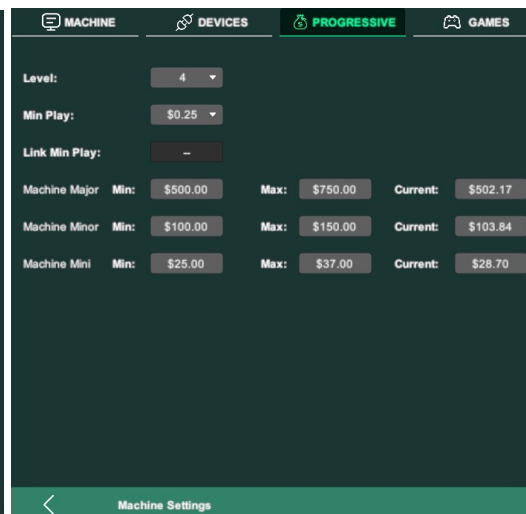

<Figure 27>

<p><b>LOCAL JACKPOT</b></p>	<p>LEVEL=The probability of winning the Jackpot, which can be adjusted to (1~8). The larger the value, the greater the chance of winning (with an initial value of 4)</p> <p>Min Play=Minimum bet to win Local Jackpot, with options ( \$ 0.25-\$ 0.5-\$ 0.75-\$ 1.00 )</p> <p>Link Min Play=Minimum bet to win community jackpot, can only be read but not changed. To change, go to Jackpot Server back-end</p> <p>Machine MAJOR: MIN = base value MAX=Maximum value (1.5~10 times the current value of MIN, default is MIN*1.5);</p> <p>Machine MINOR: MIN=base value MAX=maximum value (1.5~10 times the current value of MIN, default is MIN*1.5);</p> <p>Machine MINI: MIN=base value MAX=maximum value (1.5~10 times the current value of MIN, default is MIN*1.5);</p> <p>Current: initial value of the Jackpot: any value of Min-Max can be set, if set to *, then the final value of the Jackpot is between * and Max</p>
-----------------------------	---

#### 4) GAMES

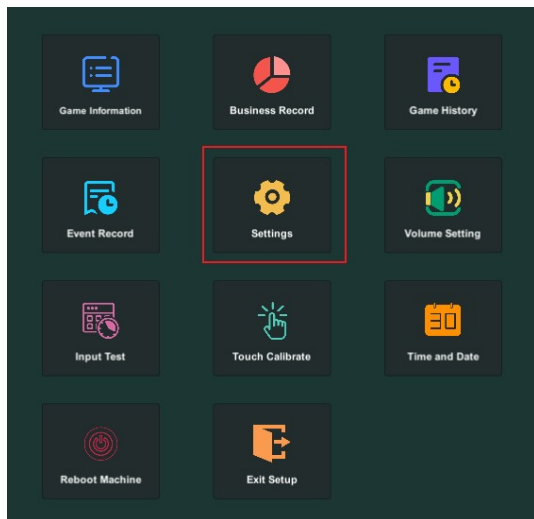

<Figure 28>

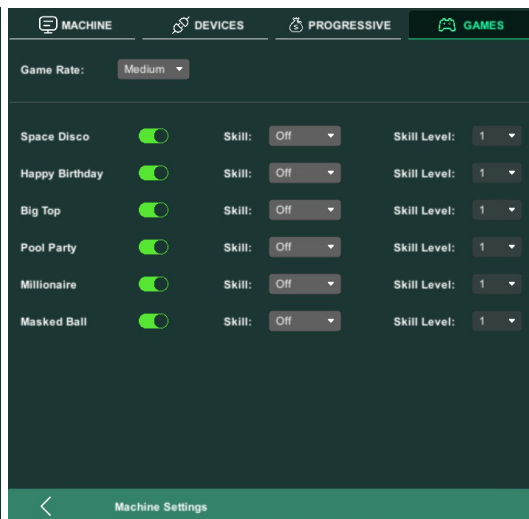

<Figure 29>

1	Game Rate	<p>Game Rate (the default game rate is medium) Adjustable: [Very Low / Low / Medium / High]</p> <p>Very Low: Game Rate is about 86%; Low: Game Rate is about 89%; Medium: Game Rate is about 92%; High: Game Rate is about 95%;</p> <p>The larger the percentage, the lower the difficulty</p>
2	Space Disco	<p><b>Left switch:</b> (Grey=OFF, Highlighted=ON) If you choose ON, the game card in the lobby will be highlighted, and you can play the game</p>
3	Happy Birthday	<p>If you choose OFF, the game cards in the lobby are grayed</p>

4	Big Top	
5	Pool Party	
6	Millionaire	
7	Masked Ball	

## 6. Volume Setting

1) Select **【Volume Setting】** to set the volume

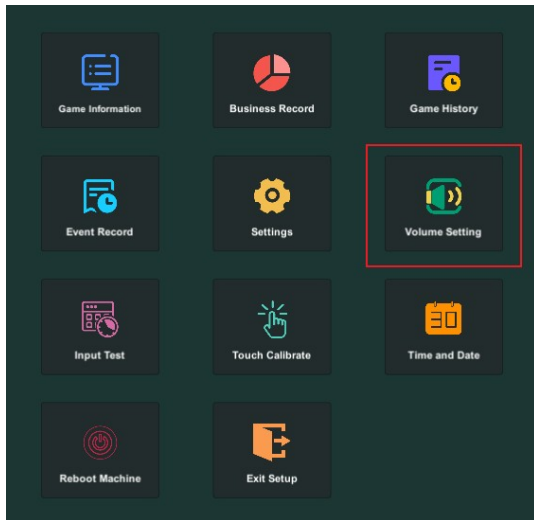

<Figure 30>

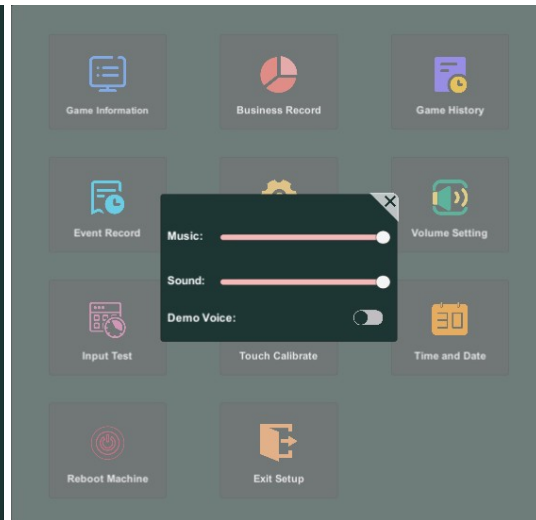

<Figure 31>

Volume Setting		
1	VOLUME	<p>Volume control (Music and Sound)</p> <p>Demo Voice:            A highlighted state (ON) indicates that there is sound in the game during demo mode            The gray state (OFF) indicates that there is no sound in the game during demo mode</p>

## 7. Input Test

1) Enter the back-end and select the **【Input Test】** to test input button

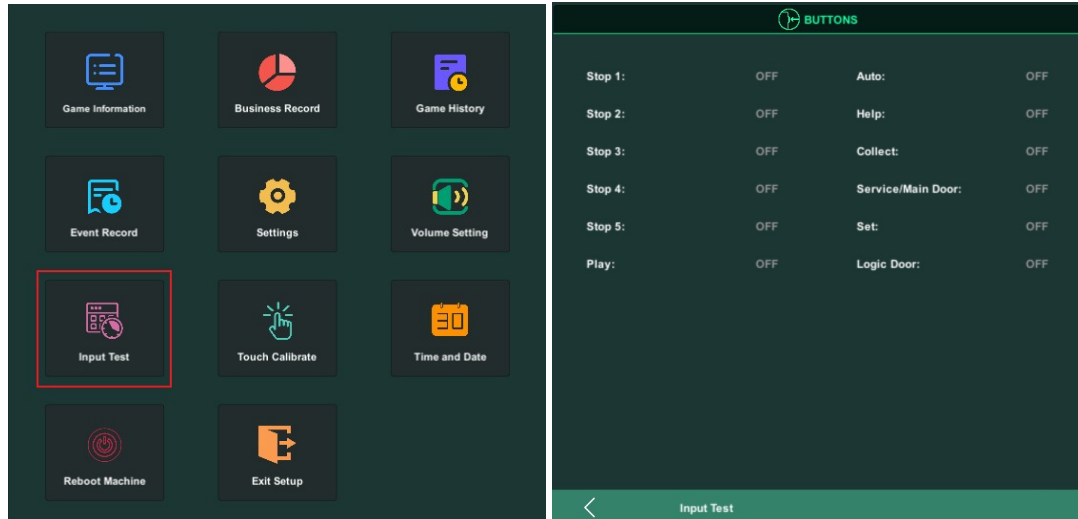

<Figure 32>

<Figure 33>

### Input Test

<h3>Input Test</h3>		
1	<b>BUTTONS</b>	There are 12 buttons can be tested. In the initial state, the grey font "OFF" is displayed to the right of the button, indicating that the button has not been pressed or turned on. Press the corresponding button, and if it works properly, the green font "ON" will be displayed on the right side of the corresponding button. As shown in<Figure 33>

## 8. Touch Calibrate

1) Enter the back-end and select **【Touch Calibrate】** to check touch calibration

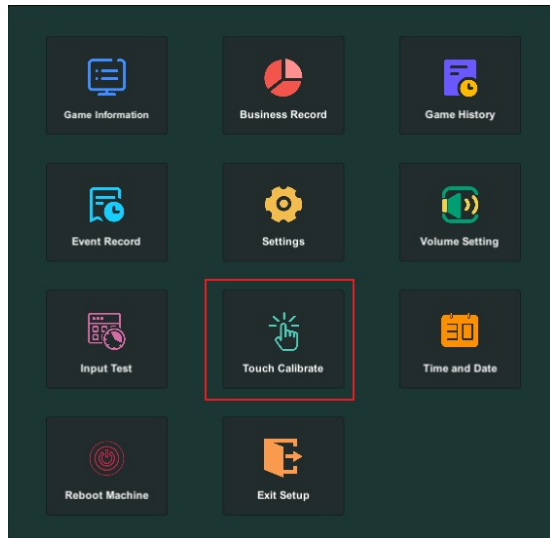

<Figure 34>

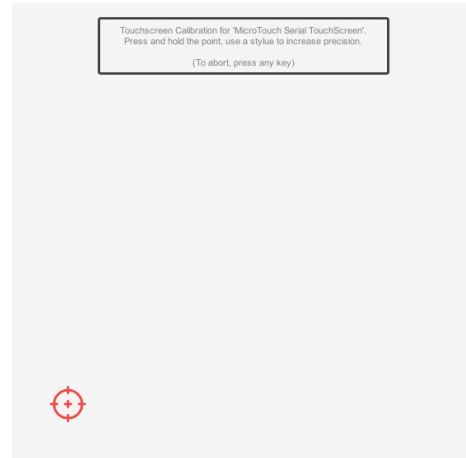

<Figure 35>

Touch Calibrate		
1	Touch Calibrate	<p>Used as an auxiliary setting for re-calibrating the touch screen when touching an inaccurate position on the screen. As shown in &lt;Figure 34&gt; and &lt;Figure 35&gt;, following the prompts on the screen (Touchscreen Calibration for 'Micro Touch Serial Touchscreen'. Press and hold the point, use a stylus to increase precision, (To abort, press any key) )</p> <p>Firstly, find the red aiming symbol in the lower left corner and hold it for 3 seconds. Then, find the red aiming symbol in the upper right corner and hold it for 3 seconds. The calibration will be completed and the system will be automatically returned to the previous menu</p>

## 9. Time and Date

1) Enter the back-end and select **【Time and Date】** to set the time and date

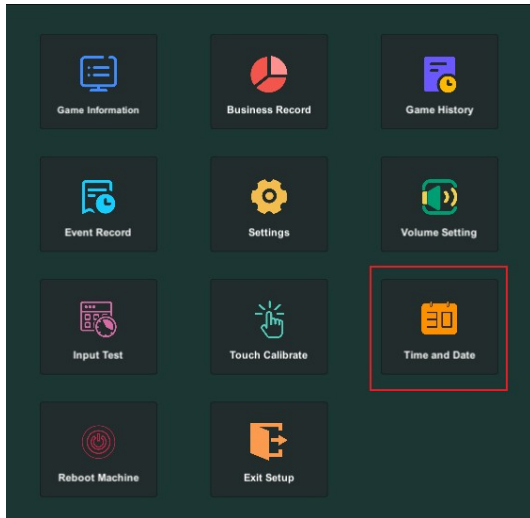

<Figure 36>

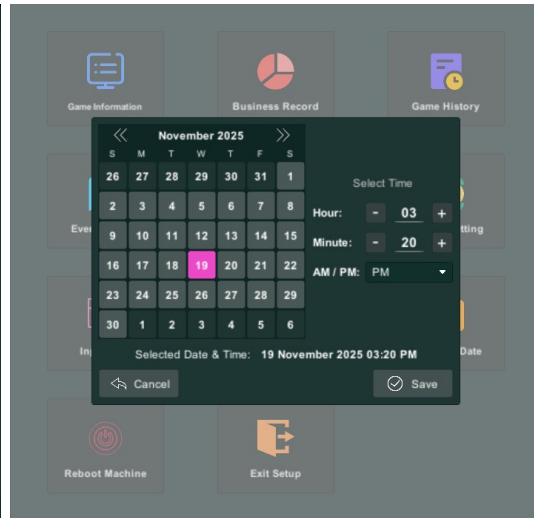

<Figure 37>

Time and Date		
1	Hour	Hour
2	Minute	Minute
3	AM/PM	AM/PM
4	Selected Date & Time	Selected Date & Time
5	Cancel	Cancel
6	Save	Save ;

## 10. Reboot Machine

1) Enter the back-end and selecting **【Reboot Machine】** will restart the game

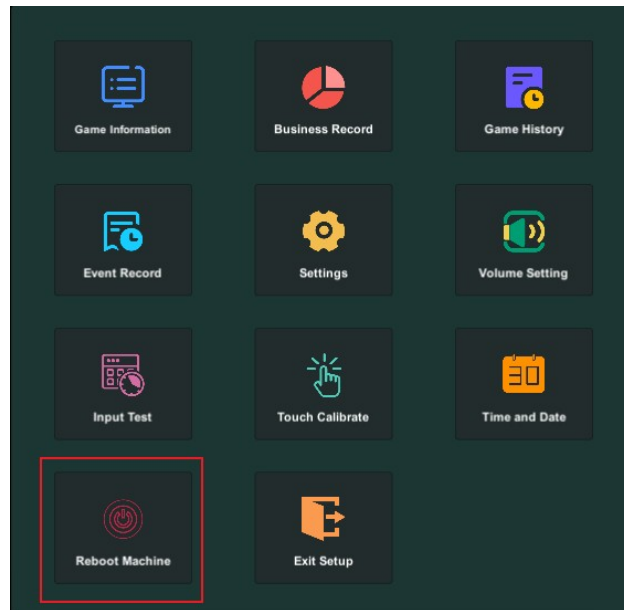

<Figure 38>

## 11. Exit Setup

- 1) Select **【Exit Setup】** to exit and return to regular game mode

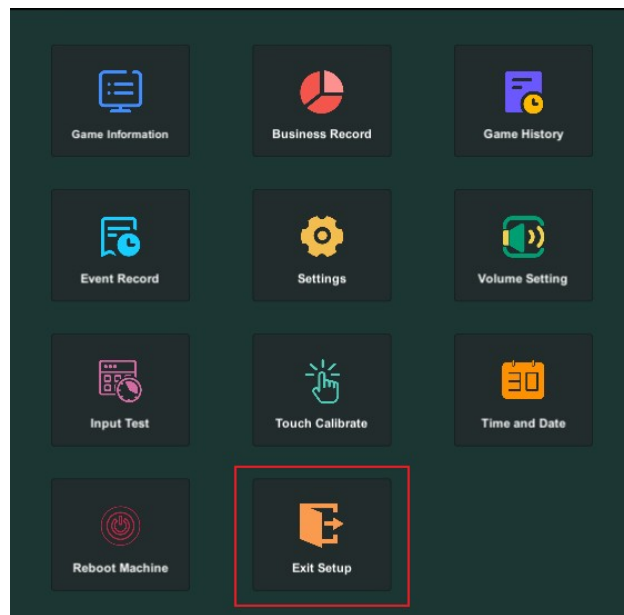

<Figure 39>

# 1. 12. Connection Diagram Of JP Sever

## Jackpot Linking Diagram

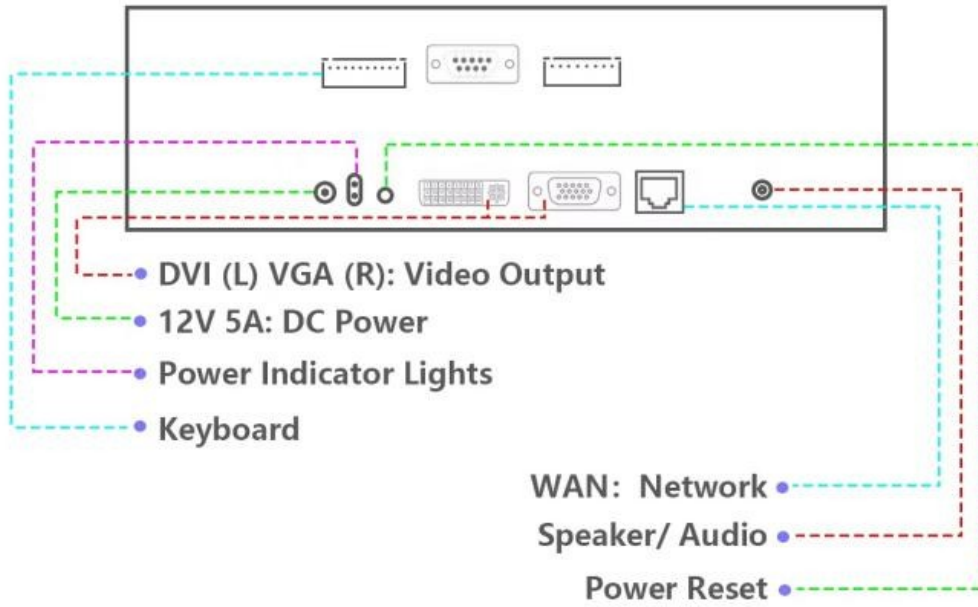

# 13. Connection Diagram Of Highand Party link 777

## Connecting Ports Fronts View

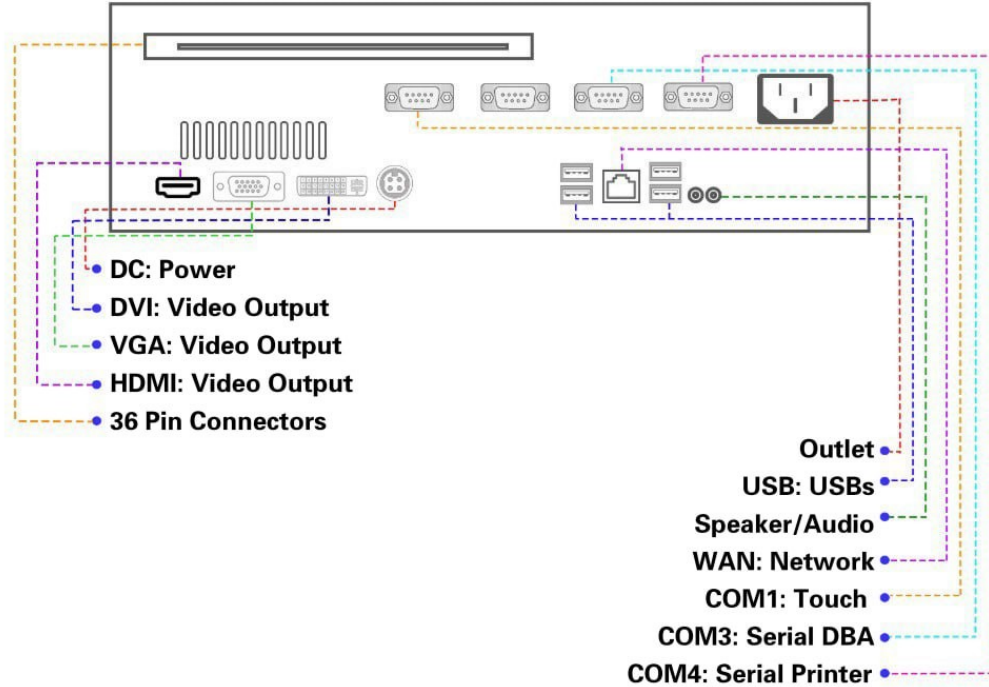

## Connecting Ports Side View

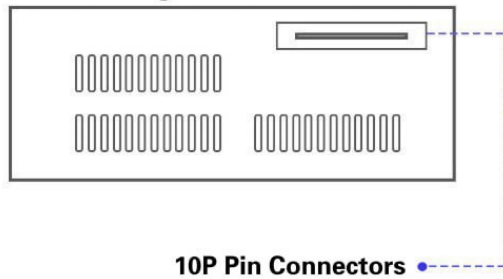







# Pin out Connection Diagram For Highend Party Link 777

## **Connection Diagram For High End Party 777**

MASTER PANDA LINK WIRE TYPE		
36 Pins		
PARTS SIDE		SOLDER SIDE
	1	
SPEAKER_R +	2	SPEAKER_R -
SPEAKER_L +	3	SPEAKER_L -
	4	SPEAKER_L -
	5	
	6	
	7	
	8	
	9	
	10	PLAY BUTTON
	11	
	12	SPEAKER_L +
	13	
	14	LOGIC DOOR SW
	15	MAIN DOOR SW
	16	TICKET LAMP
	17	
PULSE BILL IN	18	
	19	
CLERK MENU SW	20	ADMIN MENU SW
	21	TICKET BUTTON
	22	
<b>METER TOTAL IN</b>	23	
	24	DISCONNECT
	25	
	26	DISCONNECT
	27	DISCONNECT
<b>METER TOTAL OUT</b>	28	
	29	
	30	
	31	PLAY LAMP
	32	
	33	
	34	
	35	DISCONNECT
	36	

MASTER PANDA LINK WIRE TYPE		
10 Pins		
PARTS SIDE		SOLDER SIDE
GROUND	1	GROUND
GROUND	2	GROUND
+5V	3	+5V
+5V	4	+5V
+12V	5	+12V
+12V	6	+12V
	7	
	8	
GROUND	9	GROUND
GROUND	10	GROUND

## 14. Warning Prompts

Explanation		
Icon	Tips	Solution
	Bill acceptor error	Recheck the pulse or serial port
	Printer error	Recheck the pulse or serial port
	Credit in exceeded the limit	Redeem below the limit credits or setting a higher limit credits in the back-end
	Total credit out of limit	Redeem below the limit credits or setting a higher limit credits in the back-end
	Winning credit exceeded the limit	Select PASS / NO PASS buttons in the <b>【WARNING RECORD】</b>
	Linked jackpot is not connected	Connect to linked jackpot server board